

Roped/Holeless Jack Installation Instructions

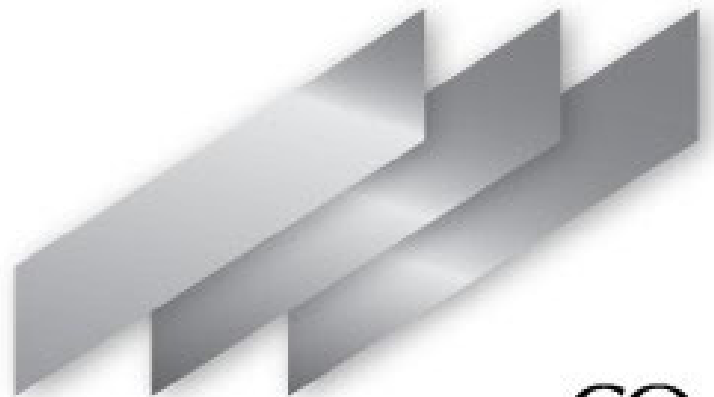

DL MARTIN CO.

Contents

UNPACKING PRECAUTIONS	3
BOTTOM SECTION INSTALLATION	3
INTERMEDIATE SECTION INSTALLATION	4
TOP SECTION INSTALLATION	8

UNPACKING PRECAUTIONS



Make sure that all shipping packing is in place at the bottom of the jack sections. If the shipping material is missing or looks like it was damaged check the plunger ends for any type of damage. Any damage (ding or scratch) may result in poor sealing surface or bad parts.

Do not hit or drop the cylinder couplings. A hit to the coupling will result in the coupling becoming egg shaped making it very difficult to take off.

Check to make sure that you remove the hardware kit and install the bleeder valve before the jack is pressurized. The bleeder hole (located on the cylinder) has a small cap installed in it; this cap keeps out dirt during shipping. This cap is **not** designed to withstand **any** pressure.

BOTTOM SECTION INSTALLATION

***** SAFETY NOTE *****

BEFORE LIFTING BOTTOM JACK SECTION, MAKE SURE THE SHIP CAP IS SECURELY FASTENED TO THE CYLINDER SECTION. IF THE SHIP CAP IS NOT ON CORRECTLY, JACK SECTION MAY FALL DURING INSTALLATION CAUSING PERSONAL INJURY OR DEATH.

1. Attach hoist equipment to the shipcap through the eyebolt of the bottom section. Move bottom section over to proper position and lower into place. Attach bottom section to mounting plate with proper hardware.



2. After the bottom section is securely mounted, remove female coupling with spanner wrench or strap wrench to expose plunger for installation of the next jack section. The female coupling is removed in a counter clockwise rotation. When removing the female coupling secure the eyebolt with a bar. This will prevent the eyebolt from turning with the female coupling. **NOTE:** *Do not unscrew top shipcap at eyebolt because it may jamb shipcap, damage plunger or plunger coupling.*

PRECAUTION: Since dust and debris can fall into the inside of the jack section after the ship cap is removed; protect the jack section by covering the opening. By keeping the inside sections clean it will help keep problems from arising in the future.

3. Once the female coupling is removed place coupling in a safe location because it will be used on the next section during the assembly process. With the eyebolt still attached securely to the plunger, raise plunger out of the cylinder section about 2' to 3'. Once the plunger is at this height, use clamps (Do not damage plunger surface) to hold it in that position. **NOTE:** *Keep items away that might damage the surface finish of the plunger. Also keep the hole between the plunger and cylinder covered at all times. Tie clean rags around the plunger to keep items from falling down inside the sections.*

PRECAUTION: Before going any further you should make sure that the plunger will not slip through the clamps when tension is released from the hoist. Lower plunger until clamps rest on cylinder. Next, lower hoisting chain until there is no tension in the chain. This will test to see if the grip on the plunger from the clamps is satisfactory. If you need to adjust the tightness of the clamps do so and repeat test.

4. Lower hoisting chains and remove chains from the plunger eyebolt shipcap. Once the shipcap is disconnected, unscrew the eyebolt shipcap from the plunger.

INTERMEDIATE SECTION INSTALLATION

FOLLOW THE NEXT STEPS IF YOUR JACK ASSEMBLY IS A 3 PIECE OR MORE. IF YOUR JACK ASSEMBLY IS ONLY A 2 PIECE, MOVE AHEAD TO STEP #28.

***** SAFETY NOTE *****

BEFORE LIFTING INTERMEDIATE JACK SECTION MAKE SURE THAT THE SHIP CAP IS SECURELY FASTENED TO THE CYLINDER SECTION. IF SHIP CAP IS NOT ON CORRECTLY JACK SECTION MAY FALL DURING INSTALLATION CAUSING PERSONAL INJURY OR DEATH.

5. Attach hoist equipment to the shipcap through the eyebolt on intermediate jack section. (If there are multiple intermediate sections make sure that the black stenciled numbers on the mating ends match. If there is a #1 stenciled on the top end of a section look for a section that a #1 is stenciled on the bottom end. The numbers need to match 1 to 1, 2 to 2, and 3 to 3 etc.) With this assembly you will need an item on your hoist setup that will allow the jack section to spin freely and not get tangled. (Exp. A turnbuckle). This is needed because the assembly process will be spinning the upper plunger onto the stationary bottom plunger.
6. Hoist jack section to proper height clearing the bottom section, align upper section over bottom section, then lower upper section to working height directly above the bottom jack section.

PRECAUTION: Upper section must be plumb and directly over the bottom section to prevent installation problems and to prevent damage to the threads on plungers.

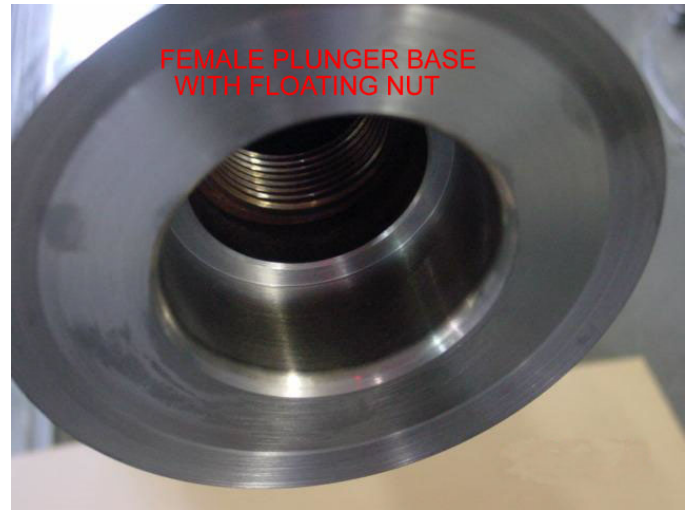
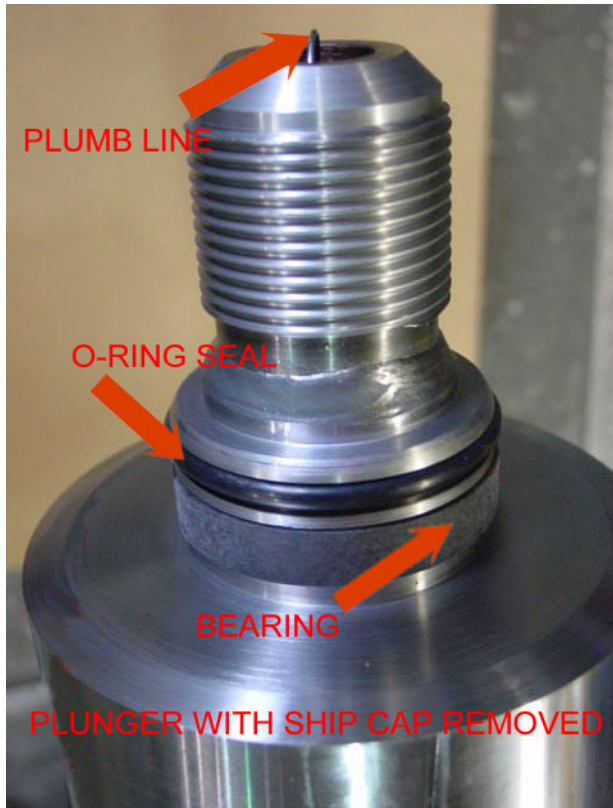

7. Remove bottom protective coating off the intermediate section. (**Note: Split rings are stored under the mesh netting beneath the protective coating. Use caution when removing coating to prevent split rings from dropping into the lower cylinder barrel***) Clean plunger area of any foreign substance with some type of solvent. Inspect plunger for dings, nicks, or scrapes. If there are any kind of blemishes please contact D.L. Martin at the number printed on the sticker on the jack assembly.



8. Remove split rings from mesh package on cylinder. Make sure rings are not bent or twisted. After packaging is removed take the female coupling that was removed in step # 3 and slide it up over the bottom of the upper section. (Threads should be pointing down.) Slide coupling up over welded shoulder on the upper cylinder section. Place split rings on lip and then lower the female coupling over the split rings. (If split rings seem to have a different radius as the cylinder, stand the ring on its end and give the other end a tap with a hammer. This will give some form back to the split rings if needed.) The female coupling will be held there while the assembly is being lowered into place.

9. Make sure o-ring and bearing are located in the bottom jack section (See top picture). Inspect the plunger and cylinder o-ring for scrapes, nicks, or blemishes. The cylinder o-ring is placed in the groove located just inside the top of the cylinder. Clean & inspect both the female and male threads on the plunger sections. If thread damage is detected, repair threads and repeat cleaning. Threads must be free of debris or damage for proper installation.



10. Apply anti-seize generously to both the male & female threads. Do not apply anti-seize to o-ring. Apply an o-ring safe silicone to the o-rings of the plunger and cylinder. Use a generous amount of silicone on o-rings, o-ring grooves, and immediate areas.

PRECAUTION: Make sure that o-ring is seated properly in its groove to prevent damage at assembly.

11. Apply Loctite Teflon Thread Lock Compound very sparingly to the tapered mating surface of the male plunger coupling. Use only enough compound to form a gasket between the 2 surfaces of the male and female plunger sections. Too much compound will cause the scribe marks not to align properly.

***** SAFETY NOTE *****

WHEN SCREWING PLUNGER SECTIONS TOGETHER PAY SPECIAL ATTENTION TO THE TOP SHIP CAP. MAKE CERTAIN THAT THE SHIP CAP IS NOT UNSCREWING FROM ELEVATED JACK SECTION. IF JACK SHIP CAP COMES LOOSE THE SECTION WILL FALL CAUSING DAMAGE TO THE JACK ASSEMBLY AND PROBABLE PERSONAL INJURY OR DEATH.

12. Carefully and slowly lower the upper jack section so the female and male plunger couplings engage.
Do not allow chain hoist to become slack.

13. Start spinning the upper section in a clockwise rotation. Making sure that the turnbuckle is spinning with the upper jack section and the chain and hoist are not getting tangled.

PRECAUTION: If any type of bind is felt STOP immediately. If you do not stop you risk the chance of damaging the threads. Unscrew the jack assembly, inspect the threads, and repair if necessary.

14. After the first thread is engaged stop and lock the turnbuckle.

15. Carefully turn upper plunger section by hand until the gap between the 2 plungers is about 1/16th of an inch; and, then raise both plunger sections up approximately 1/4th of an inch.

16. Keep turning top plunger section by hand until the scribe marks cross. Then use a strap wrench to align marks perfectly. **NOTE:** If wrench slips on plunger a piece of sand paper or rubber will help get better grip on the plunger surface.

17. Make sure there is no gap between the sections. By using 2 strap wrenches against each other you can eliminate any gap that could possibly cause damage to the seals.

PRECAUTION: If any type of bind is felt on any of the installation, STOP immediately. If you do not stop you risk the chance of damaging the threads. Unscrew the jack assembly, inspect the threads, and repair if necessary.

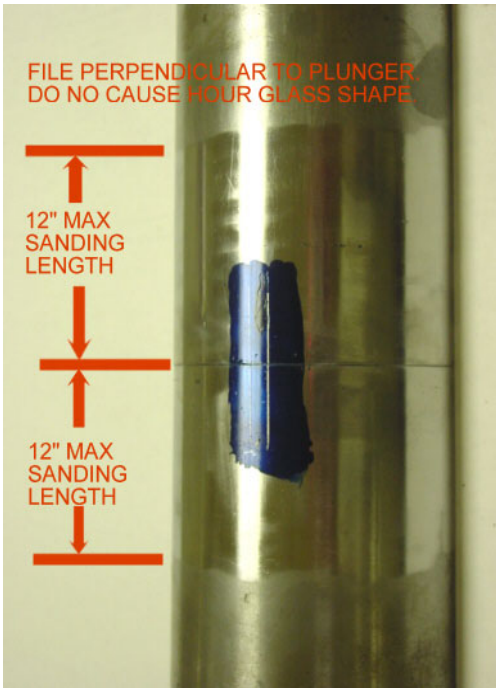

18. With rags still in place clean excess Loctite from the joint. If there is no lip experienced over the joint (fingernail should not catch on plunger joint), sanding is not necessary. Take an emery cloth or scotch-brite pad and blend in the area 6 to 12 inches above and below the joint as required.

19. If a lip is experienced remove only the high spots with a fine-tooth mill file. Do not cause hour glass shape. When sanding sections work up and down the plunger approximately 6-12 inches above and below the joint where the high spots are experienced. File perpendicular to the plunger axis. After the joint is even go over the area with a piece of emery cloth or a scotch-brite pad.

20. After the sections are together raise the upper jack section and remove the wood clamps from around the bottom plunger.

21. Check o-rings and the threads on the cylinders for nicks, scratches, or chips. Clean threads on the cylinder to make sure they are free of debris.

***** SAFETY NOTE *****

CHECK AND REWIND TURNBUCKLE IF NECESSARY SO THE UPPER JACK SECTIONS DO NOT BECOME UNFASTENED.

22. Apply an o-ring safe silicone to the o-ring inside the cylinder. Use a generous amount of silicone on o-ring, o-ring groove, and immediate area. Apply anti-seize sparingly to both the male & female threads. The anti-seize could possibly cause binding on the cylinder threads. Also use anti-seize on contact areas.

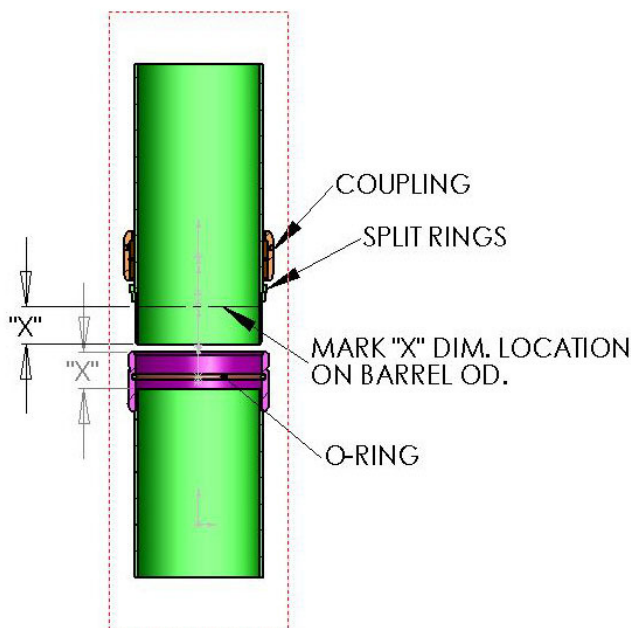

23. Check the split rings installed in step #8. They should be installed between the coupling and the shoulder welded to the cylinder. Push down on the coupling until the rings bottom out on the shoulder.

24. Measure the distance “X” between the top of the male coupling and the lower cylinder. Mark the distance on the upper cylinder so you will have an idea how close the cylinders are from touching when assembling. See drawing.

25. Lower the upper cylinder into the male cylinder coupling. Make sure the o-ring does not get pinched. Lower upper cylinder until cylinders touch. The distance marked on the cylinder in step # 24 should verify that the cylinders are touching. The upper cylinder may need to be shifted a little in order for the cylinder to be lowered fully into place.

PRECAUTION: If any type of bind is felt on any of the installation **STOP** immediately. Do not force sections together.

Possible reasons why the cylinders will not go together properly:

The eyebolt ship-cap on the plunger is partially unscrewed. The eyebolt ship-cap needs to be screwed down all the way on the upper plunger.

Plunger is not completely down on its centering pin or guides. Move plunger around to make sure it is in its proper position.

- 26. Spin female coupling on by hand as far as possible. To fully tighten use a spanner wrench or strap wrench. It is possible to see a thread at the bottom of the female coupling still exposed.
- 27. If there is another intermediate section repeat steps 5 –26.

TOP SECTION INSTALLATION

28. Top section does not have an eyebolt ship-cap. Use a sling on the outside diameter of the cylinder barrel to pick up the section. **Note: The shipping bracket should not be used to pick up the top section. The bolts are not designed to withstand shock load and twisting that may occur during installation. Top bracket is not designed to hold weight of entire plunger after plunger sections are assembled.**

29. Repeat steps 6 – 26.



30. If there are any questions, problems, or concerns please contact D.L. Martin (717) 328-2141. Please record the serial number (See attached photo for location) prior to making your call in case the D. L. Martin representative needs this number.