



# D. L. MARTIN CO.

25 D.L. Martin Drive, Mercersburg, Pennsylvania 17236

Phone (717) 328-2141 / FAX (717) 328-5437

DLM# \_\_\_\_\_

PO# \_\_\_\_\_

## ROPED AND HOLELESS JACK QUOTE/ORDER WORKSHEET

### QUOTE INFO:

FORM COMPLETED BY: \_\_\_\_\_ JOB NAME: \_\_\_\_\_ DATE \_\_\_/\_\_\_/\_\_\_

PHONE \_\_\_\_\_ - \_\_\_\_\_ - \_\_\_\_\_ FAX \_\_\_\_\_ - \_\_\_\_\_ - \_\_\_\_\_ EMAIL \_\_\_\_\_

EXISTING JACK SIZE (If replacement jack order): (plunger diameter) \_\_\_\_\_ X (wall thickness) \_\_\_\_\_

TOTAL STROKE (Floor to Floor Travel + Top Runby + Bottom Under travel): \_\_\_\_\_

Bottom Undertravel= Bottom Runby + Buffer Stroke + Tolerance Needed

COLLAPSED LENGTH: \_\_\_\_\_

TOP RUNBY: \_\_\_\_\_ BOTTOM RUNBY: \_\_\_\_\_

CAR WEIGHT: \_\_\_\_\_ CAR CAPACITY: \_\_\_\_\_

\* Car weight can be estimated for quoting purposes. However, the customer is responsible for verifying the actual car weight does not exceed the estimate. Failure to make sure the car weight figure is adequate can result in an insufficient jack being purchased for the job.

HOLELESS JACK

ROPED JACK

ROPED OR HOLELESS JACK:

- Dual Jack Configuration
- Single Jack Configuration
- Stop Sleeve/Ring (Current Travel with Sleeve \_\_\_\_\_)

ROPED JACK ONLY:

INLET:  Side Inlet  Bottom Inlet

# OF SECTIONS: \_\_\_\_\_

\_\_\_\_\_

BILL TO: \_\_\_\_\_

\_\_\_\_\_

\_\_\_\_\_

SHIP TO:

SAME AS BILL TO

\_\_\_\_\_

\_\_\_\_\_

\_\_\_\_\_

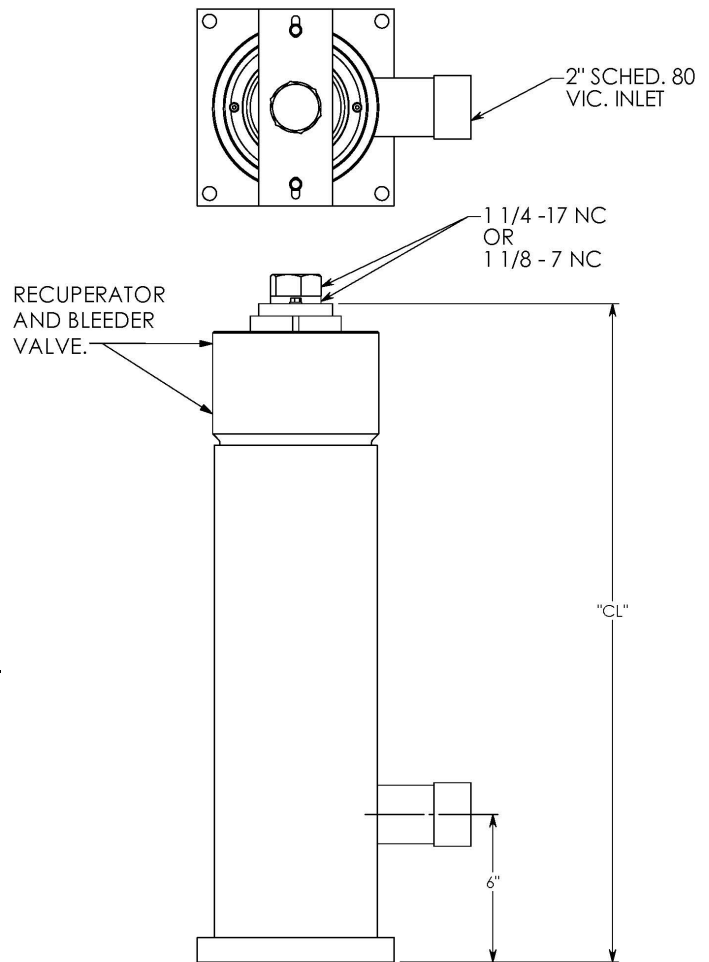

TYP. SIDE INLET HOLELESS JACK SHOWN

**NOTICE:** Failure to provide all requested information could result in delays, once the jack order is placed. A final jack layout approval sheet will be faxed to the person completing this form before the jack goes into production. If the order is for a replacement jack please provide any drawings or documentation, from the original jack, that may be useful.